

11731 Caroline Road

PHILADELPHIA, PENNSYLVANIA

FOR LEASE OR PURCHASE — BUILD TO SUIT OPPORTUNITY

ABILITY TO BUILD UP TO 60' CLEAR, BY RIGHT

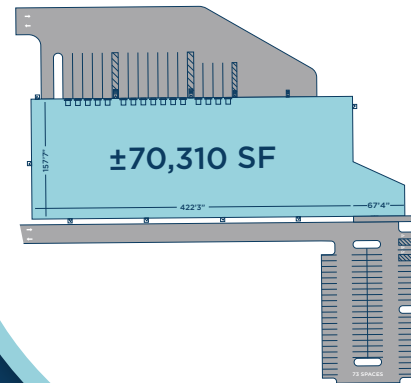

70,310 SF

INDUSTRIAL DEVELOPMENT SITE



Institutional ownership

Immediate access to **Route 1, PA-63, I-95** and **I-276**

18 Miles from Center City Philadelphia

21 Miles from Port of Philadelphia

26 Miles from PHL International Airport

JONAS SKOVDAL
Executive Managing Director
610 772 2005
jonas.skovdal@cushwake.com

CHRIS BUTERA
Director
215 963 4011
chris.butera@cushwake.com

SEAN DUNCAN
Senior Associate
610 484 4793
sean.duncan@cushwake.com



11731

Caroline Road

PHILADELPHIA, PA

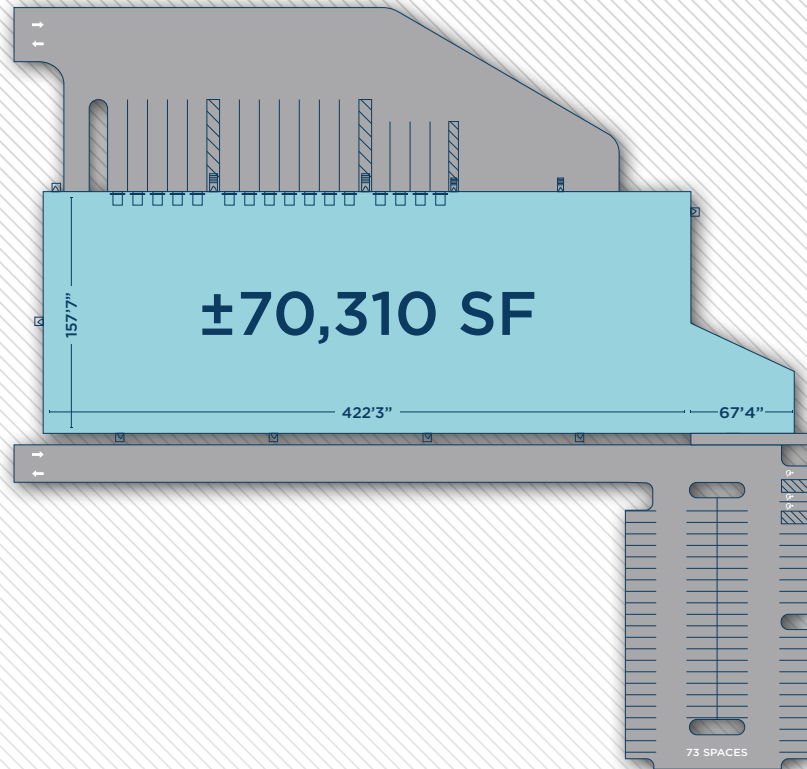

BUILDING SPECS

SF AVAILABLE	70,310 SF
BUILDING DIMENSIONS	157'7" x 422'3"
OFFICE	To-Suit
LOT SIZE	12.46 acres
TRUCK COURT DEPTH	120'
CAR PARKING	73 Car Parking Spaces
DOCK DOORS	16 Doors
DRIVE-IN DOORS	1 Door
CLEAR HEIGHT	To-Suit (ability to build up to 60' clear, by right)
COLUMN SPACING	52' x 48'-9½" (58'3" at speed bay)
SPRINKLER SYSTEM	ESFR

JONAS SKOVDAL
Executive Managing Director
610 772 2005
jonas.skovdal@cushwake.com

CHRIS BUTERA
Director
215 963 4011
chris.butera@cushwake.com

SEAN DUNCAN
Senior Associate
610 484 4793
sean.duncan@cushwake.com

 NORTHBRIDGE

 CUSHMAN & WAKEFIELD

11731 Caroline Road

PHILADELPHIA, PA

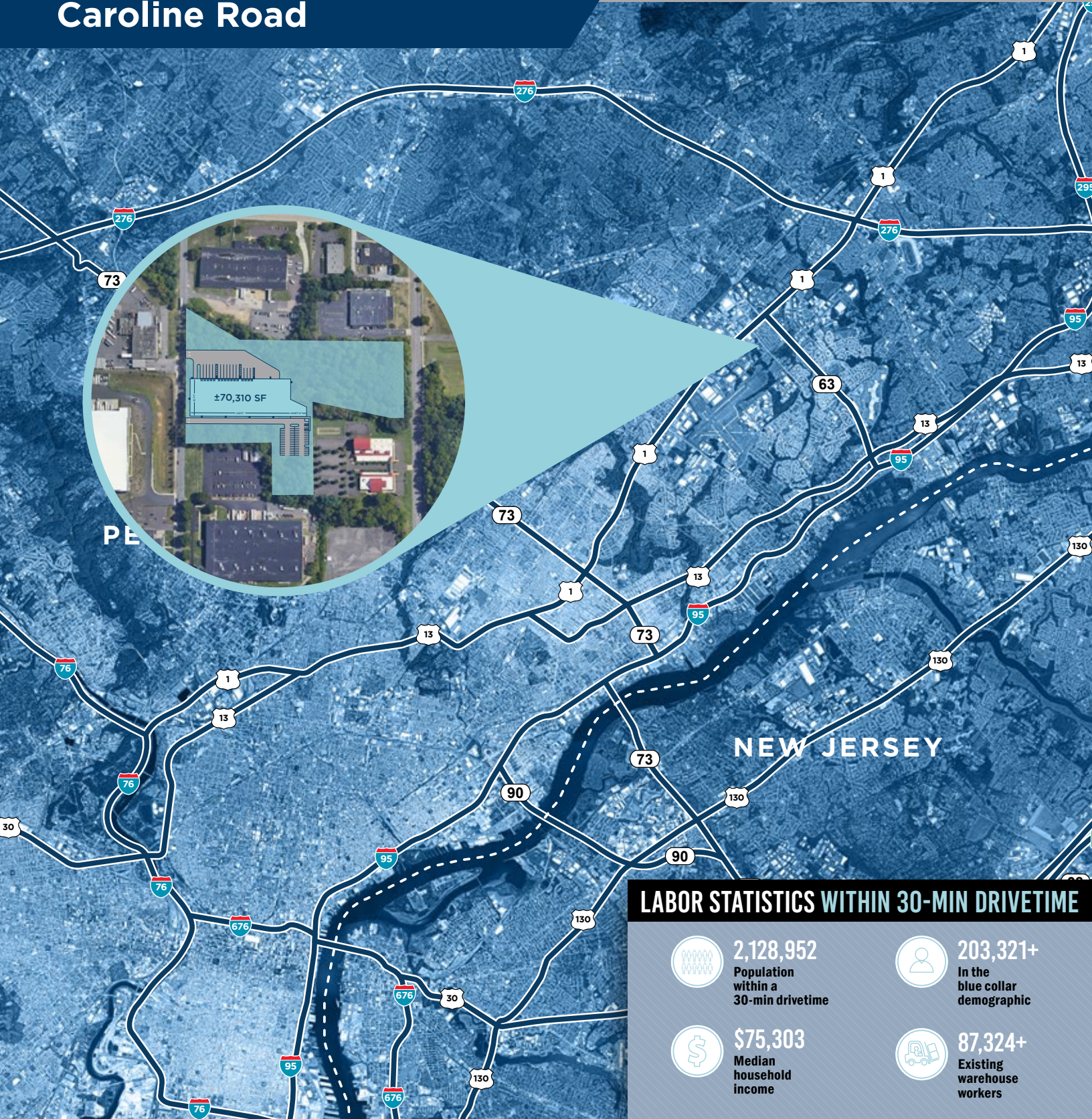

JONAS SKOVDAL
Executive Managing Director
610 772 2005
jonas.skovdal@cushwake.com

CHRIS BUTERA
Director
215 963 4011
chris.butera@cushwake.com

SEAN DUNCAN
Senior Associate
610 484 4793
sean.duncan@cushwake.com

 NORTHBRIDGE

 CUSHMAN & WAKEFIELD