

# JETPORT COMMERCE PARK

Benjamin Rd. & Jetport Industrial Blvd. Tampa, FL 33634



**DOCK HIGH & GRADE LEVEL LOADING**

# JETPORT COMMERCE PARK

Benjamin Rd. & Jetport Industrial Blvd. Tampa, FL 33634



## PROPERTY HIGHLIGHTS

- 2,400 SF up to 4,500 SF Available
- 18' Minimum Clear Height
- Dock High and Grade Level Loading
- Tilt-Wall Construction
- Fully Sprinklered

**Veterans Expressway  
Visibility and Frontage  
on Benjamin Road**

Bldg 513	Suite 6003
Office:	733 SF
Warehouse:	1,667 SF
Total:	2,400 SF

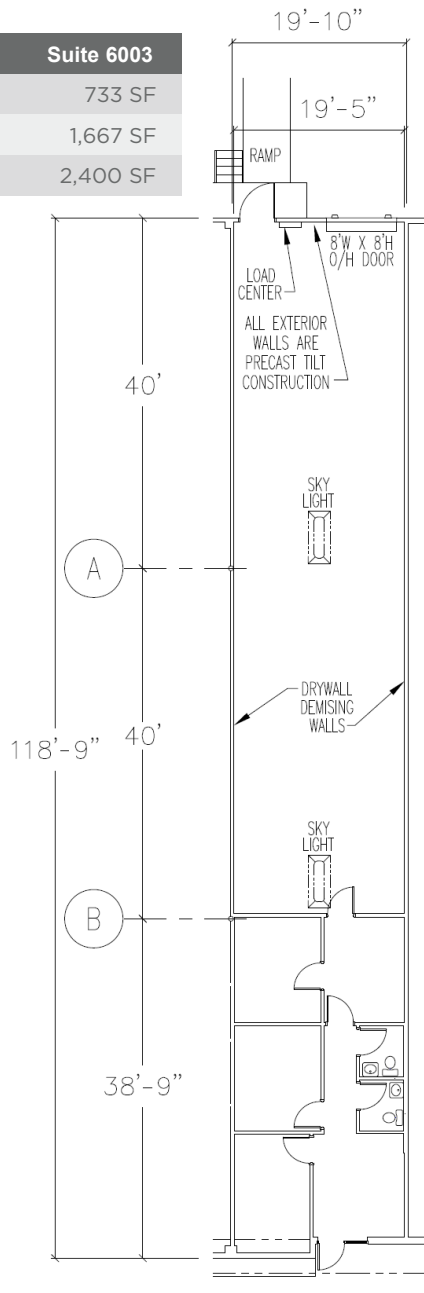

Bldg 516	Suite 6036
Office:	1,218 SF
Warehouse:	1,282 SF
Total:	2,500 SF

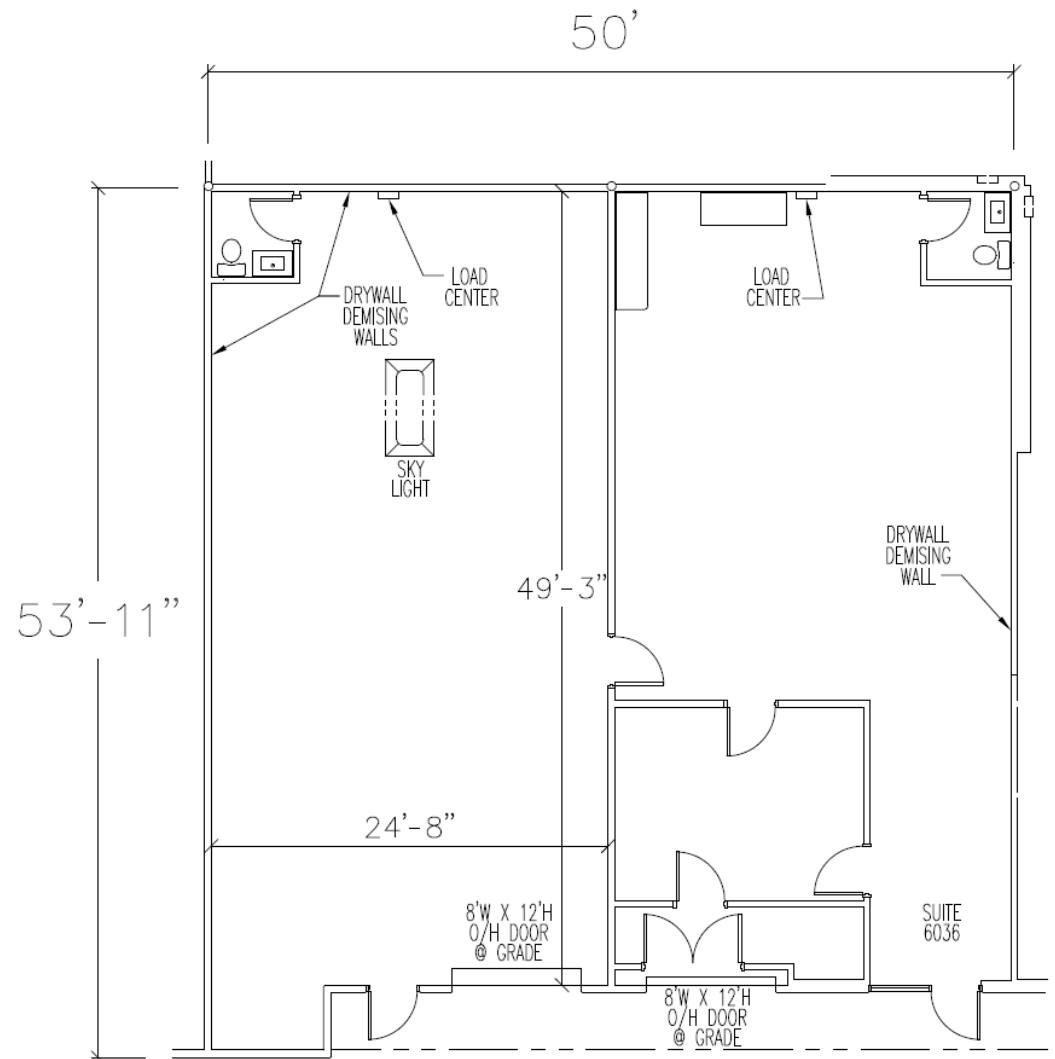

## FOR ADDITIONAL INFORMATION, PLEASE CONTACT:

**TREY CARSWELL, SIOR**  
 Senior Director  
 +1 813 204 5314  
 trey.carswell@cushwake.com

**LISA ROSS, SIOR**  
 Senior Director  
 +1 813 424 3211  
 lisa.ross@cushwake.com

One Tampa City Center  
 Suite 3300  
 Tampa, FL 33602  
 cushmanwakefield.com



Bldg 516	Suite 6006
Office:	1,200 SF
Warehouse:	1,800 SF
Total:	3,000 SF

Contiguous to  
7,000 SF

Bldg 516	Suite 6004
Office:	1,000 SF
Warehouse:	3,000 SF
Total:	4,000 SF

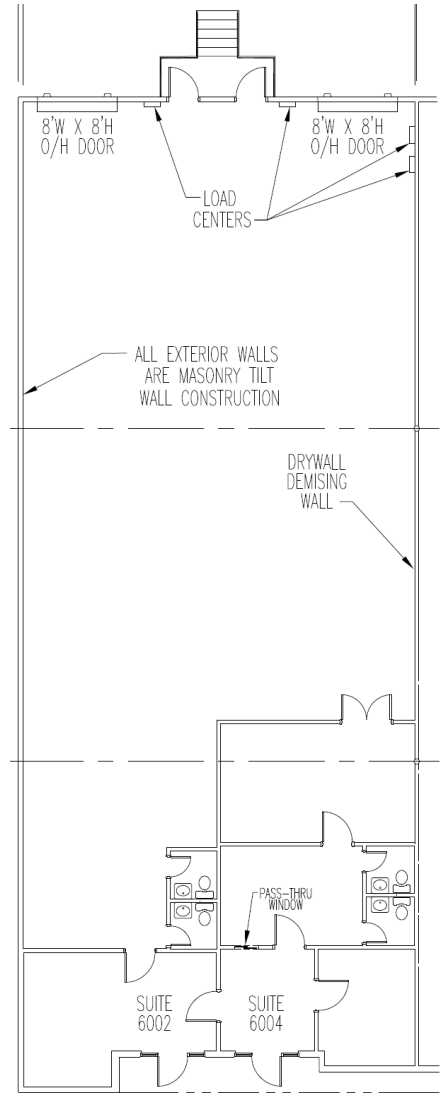
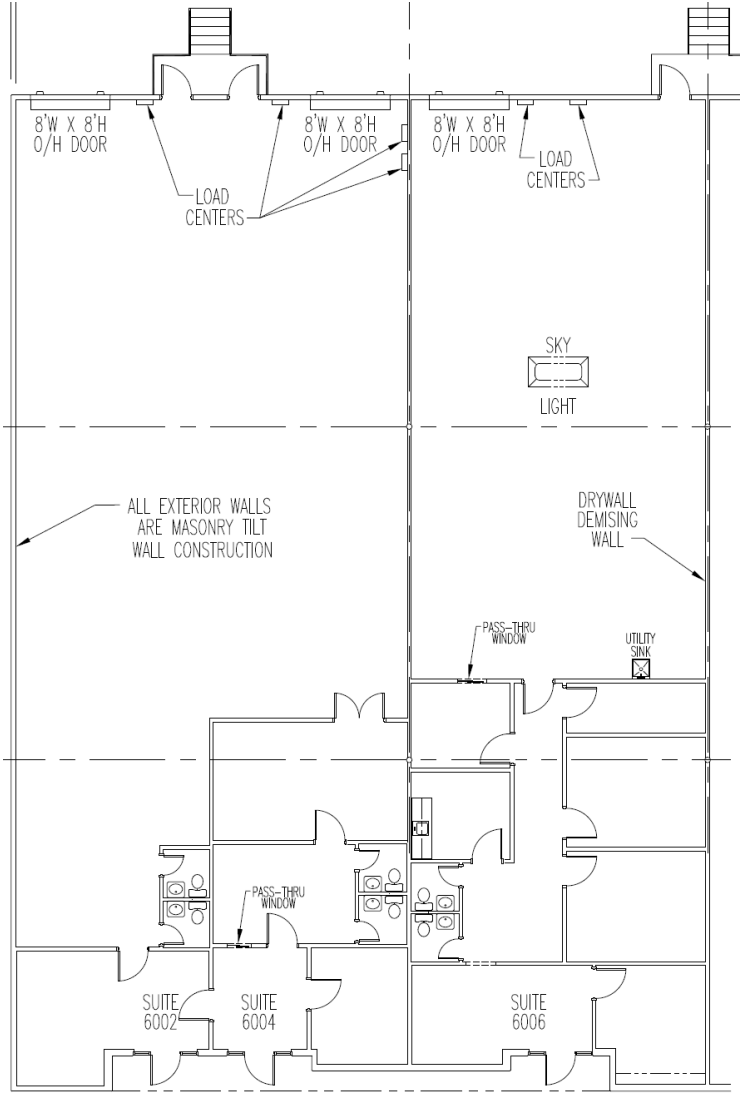
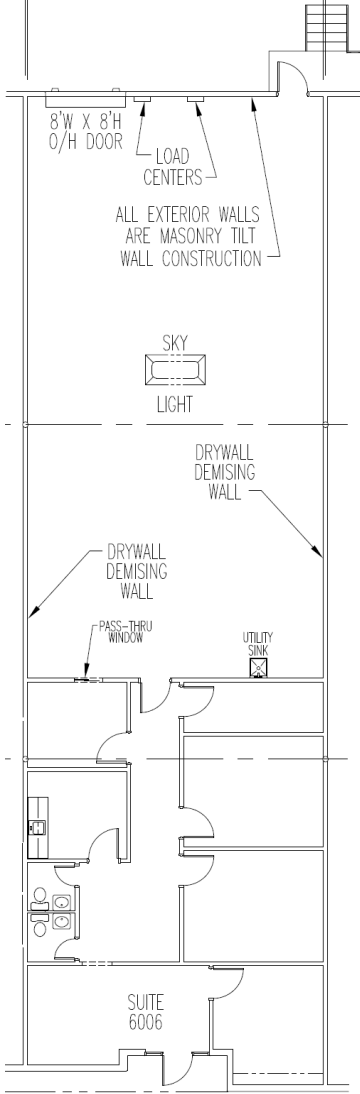

## FOR ADDITIONAL INFORMATION, PLEASE CONTACT:

**TREY CARSWELL, SIOR**  
Senior Director  
+1 813 204 5314  
trey.carswell@cushwake.com

**LISA ROSS, SIOR**  
Senior Director  
+1 813 424 3211  
lisa.ross@cushwake.com

One Tampa City Center  
Suite 3300  
Tampa, FL 33602  
cushmanwakefield.com



Bldg 515	Suite 5902
Office:	573 SF
Warehouse:	3,927 SF
Total:	4,500 SF

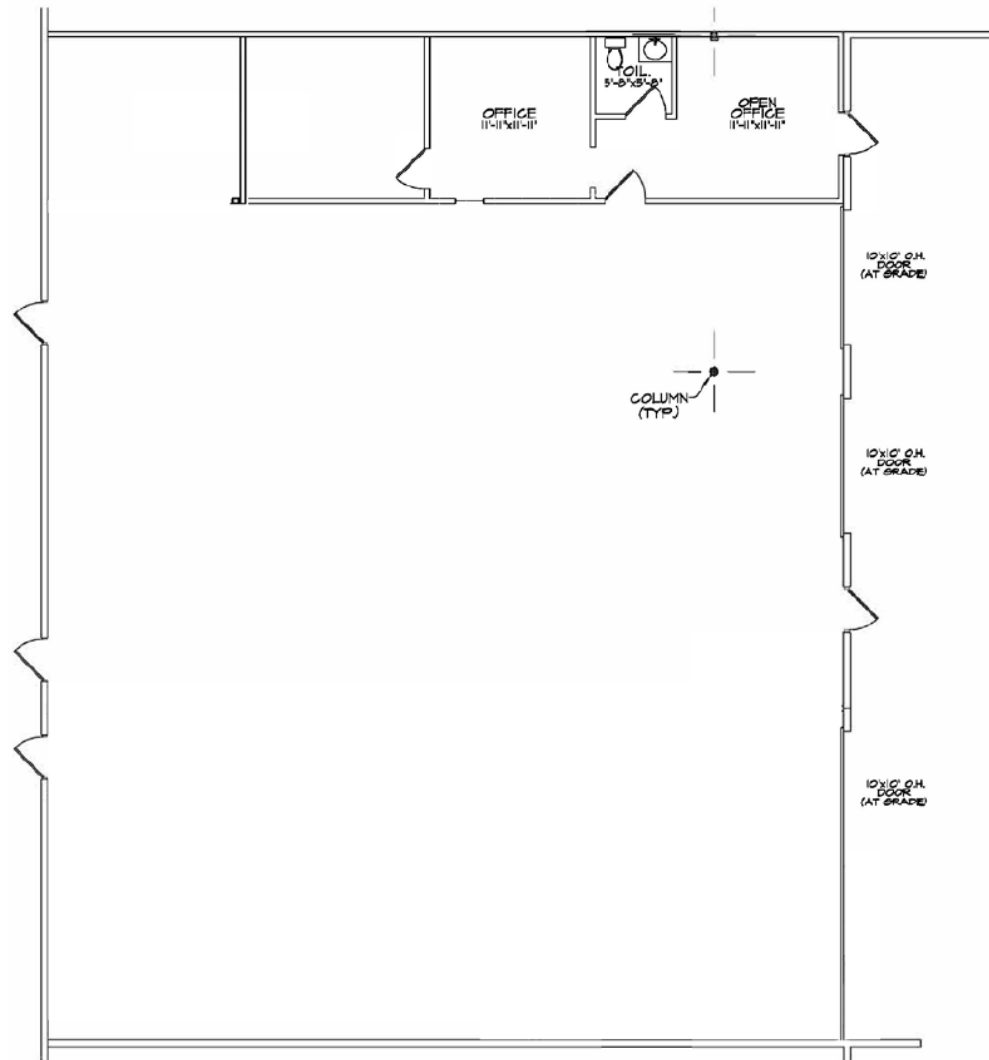

## FOR ADDITIONAL INFORMATION, PLEASE CONTACT:

**TREY CARSWELL, SIOR**  
 Senior Director  
 +1 813 204 5314  
 trey.carswell@cushwake.com

**LISA ROSS, SIOR**  
 Senior Director  
 +1 813 424 3211  
 lisa.ross@cushwake.com

One Tampa City Center  
 Suite 3300  
 Tampa, FL 33602  
 cushmanwakefield.com

