

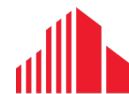

RETAIL SPACE | FOR SUBLEASE

**1326
HURON
STREET
UNIT 102**

London, ON N5V 2E2

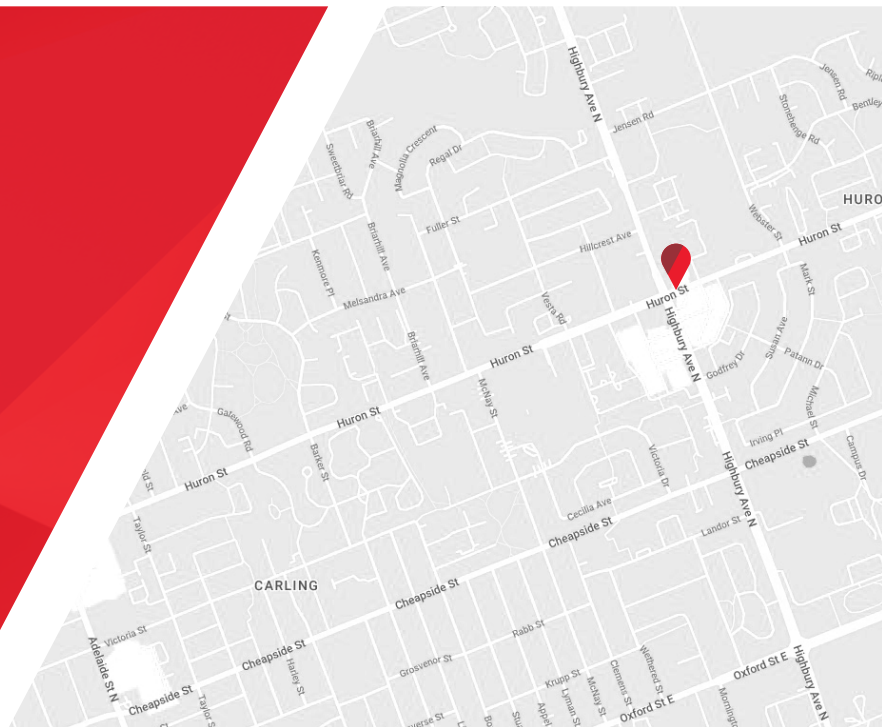

**CUSHMAN &
WAKEFIELD**

Southwestern Ontario

ABOUT THE PROPERTY

This bright, open space offers a blank canvas, perfect for a variety of retail, medical, or office purposes

UNIT	AVAILABLE SPACE	ASKING RENT	ADDITIONAL RENT
102	1,118 SF	\$24.00 PSF Net	\$10.56 PSF (2024)

- Zoning: ASA1/ASA3
- Asking rent: \$3,219.84 per month + HST and utilities
- Head lease expires on August 31st, 2027
- One, 5-year option (August 31st, 2032) with six months (February 28th, 2027) prior written notice

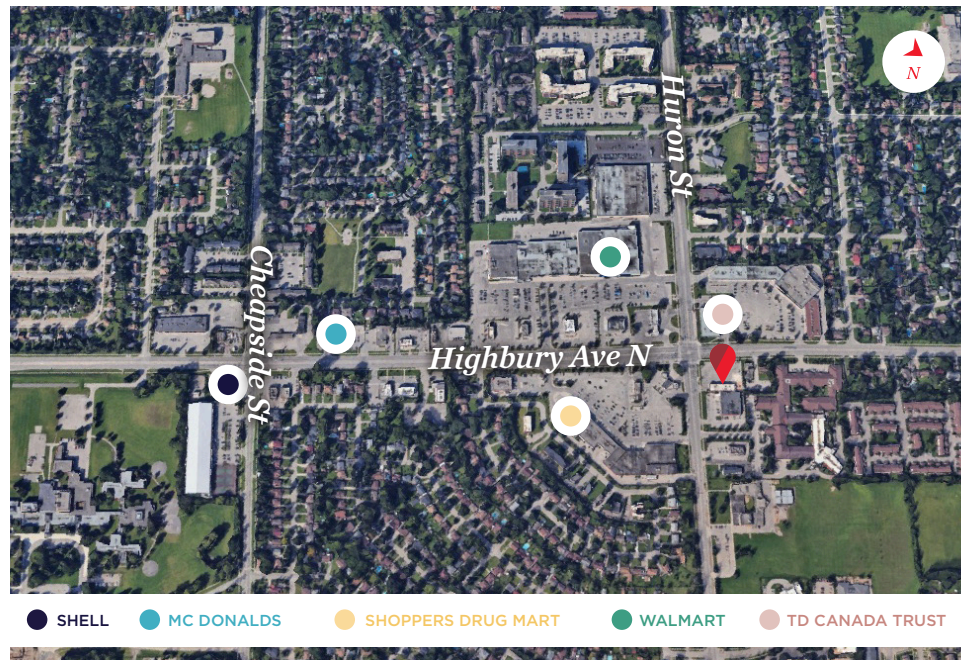
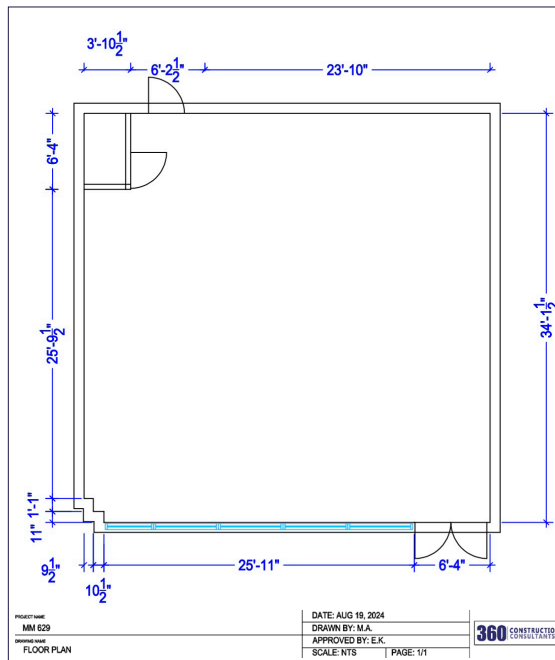

JAMESON LAKES

Sales Representative

519 438 8548

jameson.lake@cushwakeswo.com

CUSHMAN & WAKEFIELD
 SOUTHWESTERN ONTARIO
 850 Medway Park Dr, Suite 201
 London, Ontario N6G 5C6
 www.cushwakeswo.com

