



FOR LEASE

PRIME DOWNTOWN OFFICE/WAREHOUSE/STORAGE BUILDING

**180
SIMCOE
STREET**

London, ON N6B 1H9

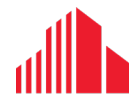

**CUSHMAN &
WAKEFIELD**

Southwestern Ontario

ABOUT THE PROPERTY

Prime downtown commercial/office building with rear storage/warehouse units available for lease

- **Zoning:** RO1
- Former Labatts offices
- Excellent for professional office/medical/clinics, tech companies etc.
- Landlord completely renovated and updated the interior of the building
- Alarm/security system is in place

OFFICE UNITS

UNIT	AVAILABLE SPACE	ASKING RENT	ADD'L, RENT	ADD'L, COMMENTS
MAIN FLOOR	Approx. 1,742 SF	\$12.00 PSF Net	\$6.75 PSF (Est.)*	\$2,721 per month + HST
LOWER LEVEL	Approx. 1,742 SF	\$7.00 PSF Net	\$6.75 PSF (Est.)*	\$1,996 per month + HST

*Inclusive of Net rent, TMI, utilities, garbage, security alarm and janitorial

WAREHOUSE/STORAGE UNITS

UNIT	AVAILABLE SPACE	ASKING RENT	ADD'L, COMMENTS
A	446 SF	\$950 per month + HST	Grade loading door
B	731 SF	\$1,460 per month + HST	Grade loading doors
C	848 SF	\$1,825 per month + HST	Grade loading doors



AMPLE PARKING ONSITE

Available on-site
for free



OPEN CONCEPT LAYOUT

Allowing a collaborative,
versatile space



PRIME LOCATION

In close proximity to
Richmond Row

TYLER DESJARDINE

Sales Representative

519 438 5403

tyler.desjardine@cushwakeswo.com

CUSHMAN & WAKEFIELD
SOUTHWESTERN ONTARIO
850 Medway Park Dr, Suite 201
London, Ontario N6G 5C6
www.cushwakeswo.com



**CUSHMAN &
WAKEFIELD**

Southwestern Ontario

PROPERTY IMAGES

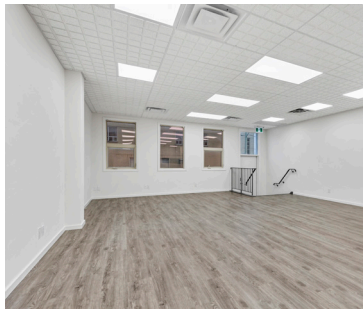
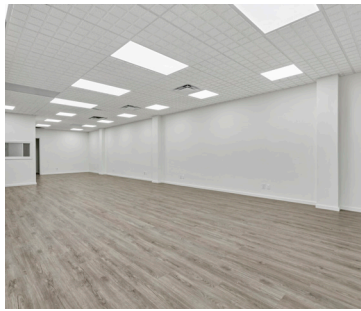

TYLER DESJARDINE

Sales Representative

519 438 5403

tyler.desjardine@cushwakeswo.com

CUSHMAN & WAKEFIELD
SOUTHWESTERN ONTARIO
850 Medway Park Dr, Suite 201
London, Ontario N6G 5C6
www.cushwakeswo.com



CUSHMAN & WAKEFIELD

Southwestern Ontario

©2024 Cushman & Wakefield Southwestern Ontario, Real Estate Brokerage, Independently Owned and Operated. A Member of the Cushman & Wakefield Alliance. This information has been obtained from sources believed to be reliable but has not been verified. No warranty or representation, express or implied, is made as to the condition of the property (or properties) referenced herein or as to the accuracy or completeness of the information contained herein, and same is submitted subject to errors, omissions, change of price, rental or other conditions, withdrawal without notice, and to any special listing conditions imposed by the property owner(s). Any projections, opinions or estimates are subject to uncertainty and do not signify current or future property performance. All rights reserved.

FLOOR PLANS

MAIN FLOOR

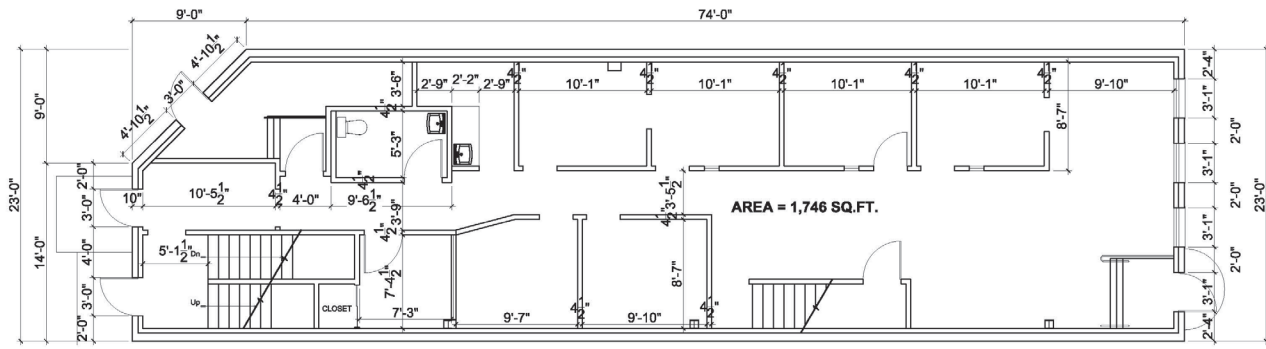

BASEMENT

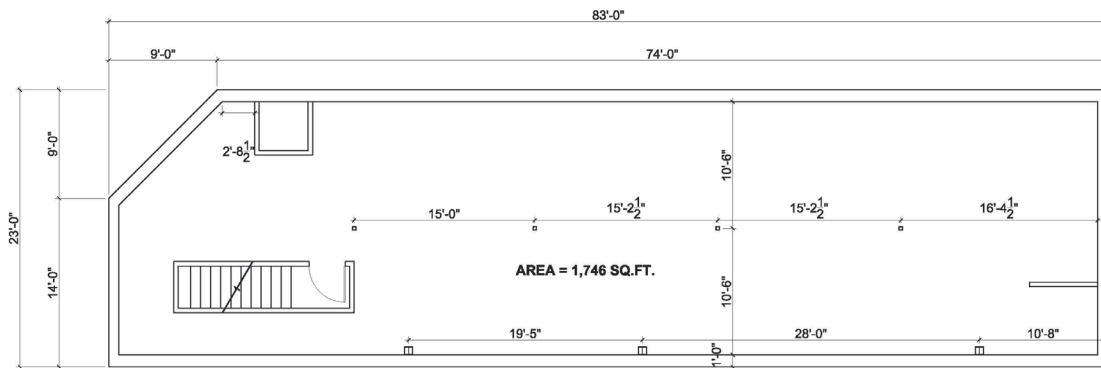

REAR WAREHOUSE

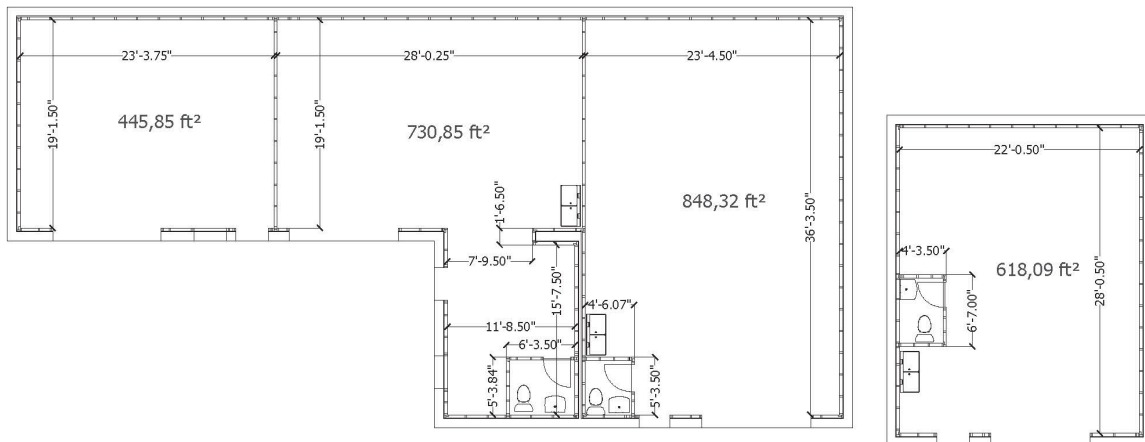

TYLER DESJARDINE

Sales Representative

519 438 5403

tyler.desjardine@cushwakeswo.com

CUSHMAN & WAKEFIELD
SOUTHWESTERN ONTARIO
 850 Medway Park Dr, Suite 201
 London, Ontario N6G 5C6
 www.cushwakeswo.com



CUSHMAN & WAKEFIELD

Southwestern Ontario