



GREYLYN

BUSINESS PARK

DESIGNED TO ACCOMMODATE ALL YOUR BUSINESS NEEDS



PROPERTY OVERVIEW

Greylyn is a premier business park located in southeast Charlotte. Designed to accommodate all your company needs, the site comprises 55 acres of high-quality office, flex, industrial and retail units suitable for a diverse range of business types.

Prominently situated adjacent to McAlpine Creek Park and the McAlpine greenway/trail, the property is set within a beautifully landscaped area, offering a welcoming park environment in which to grow your business.

As a tenant of Greylyn, you will enjoy the benefits of convenient access to downtown Charlotte as well as a wealth of retail, dining and leisure facilities right on your doorstep. Leading tenants who are already calling Greylyn their home are an inspiring mix of retail, professional business practices, media and technology companies that provide a thriving environment for your company to flourish.



YOU' RE IN GOOD COMPANY

Ella B Candles
WorldPac
Alphagraphics
Crown Point Family Practice
Mirrormate
AECOM
Live Events
CrossFit Charlotte, LLC
Crossway
Ultimate Bicycle
Charlotte Swim Academy
Woodplay
White Knight



PROPERTY HIGHLIGHTS

- Fully flexible office, retail and warehouse space.
- 850 square feet of complimentary conference room available for all tenants.
- Excellent signage and frontage on Monroe Road.
- Onsite property management with prompt customer service; abundant parking.
- Superior access to Independence Expressway, I-485, Uptown Charlotte and the Southpark area.
- Retail options nearby such as the Galleria Shopping Center.
- Extensive onsite amenities include printing and packaging, Crossfit and the Charlotte Swim Academy.





GREYLYN
BUSINESS PARK

**INTERACTIVE
SITE-PLAN**

 AVAILABLE

 OCCUPIED

 VIEW FLOOR
PLANS

 VIEW ON GOOGLE MAPS

DOWNLOADS

 FLOOR PLANS

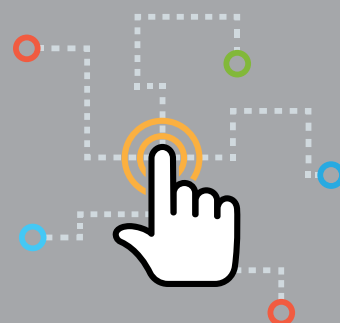

LOCATION HIGHLIGHTS

- Prominent location with excellent access via I-485 loop to Charlotte city center and the area.
- Close proximity to Matthews Township and Charlotte/Monroe Executive Airport.
- Strong retail base within a 1 mile radius includes the Galleria Shopping Center.
- Within 6.5 miles of the Pine Lake Country club.



9101 MONROE ROAD - SUITE 110



Total Available SF: SUITE 110 2,575 SF

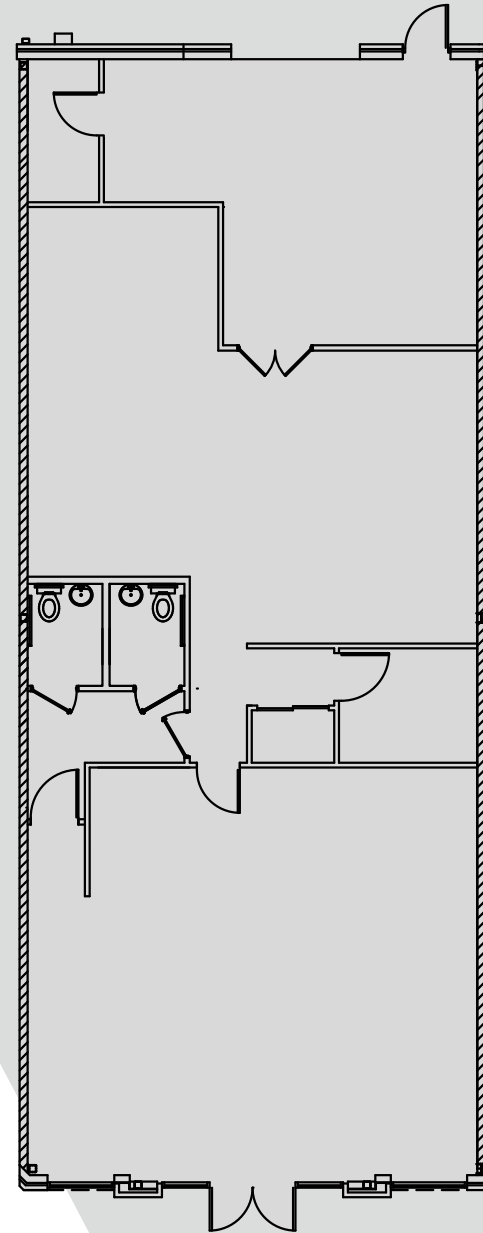



9105 MONROE ROAD



Total Available SF: 5,873 SF - 11,747 SF
Possible demise

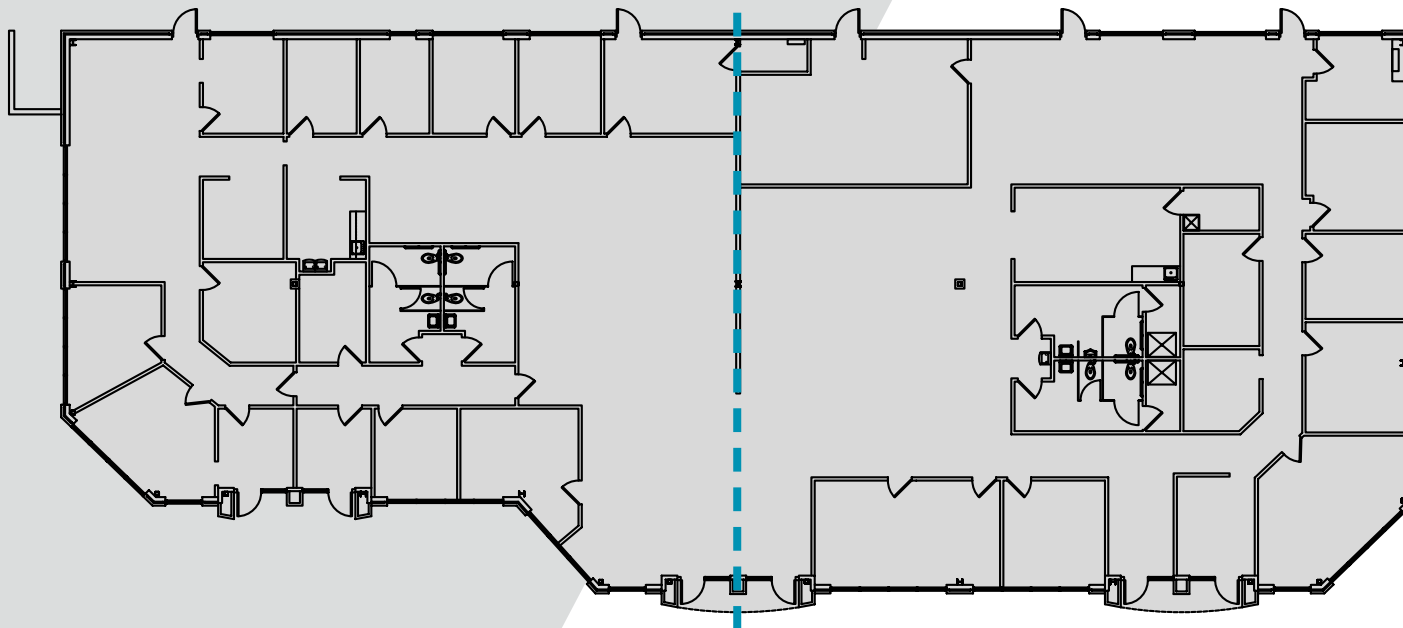



9111 MONROE ROAD - SUITE 190



Total Available SF: 1,142 SF

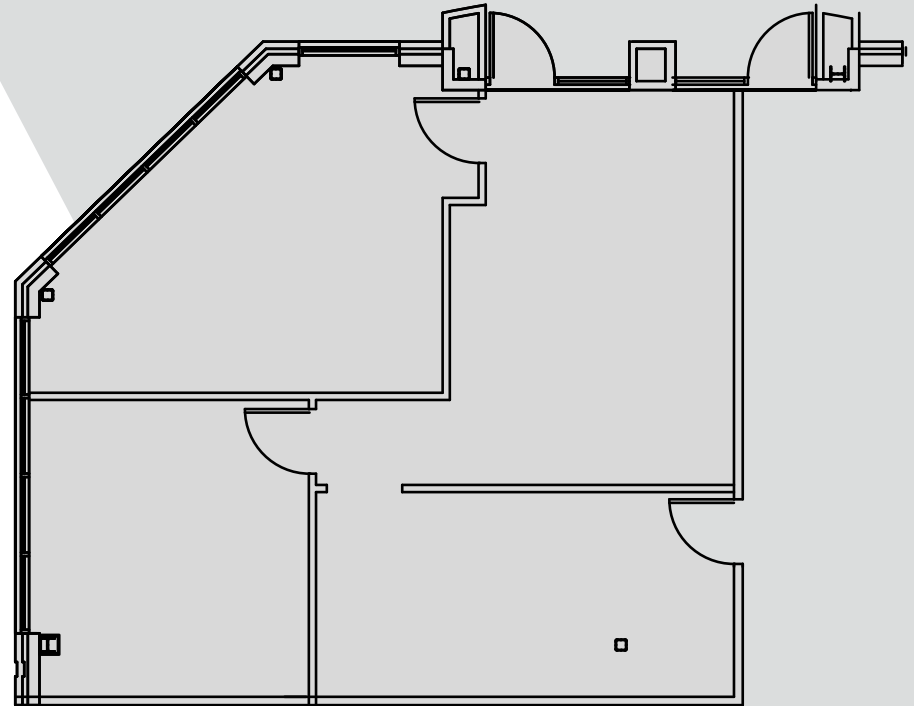



9117 MONROE ROAD - SUITES 140-190



Total Available SF: 22,075 SF

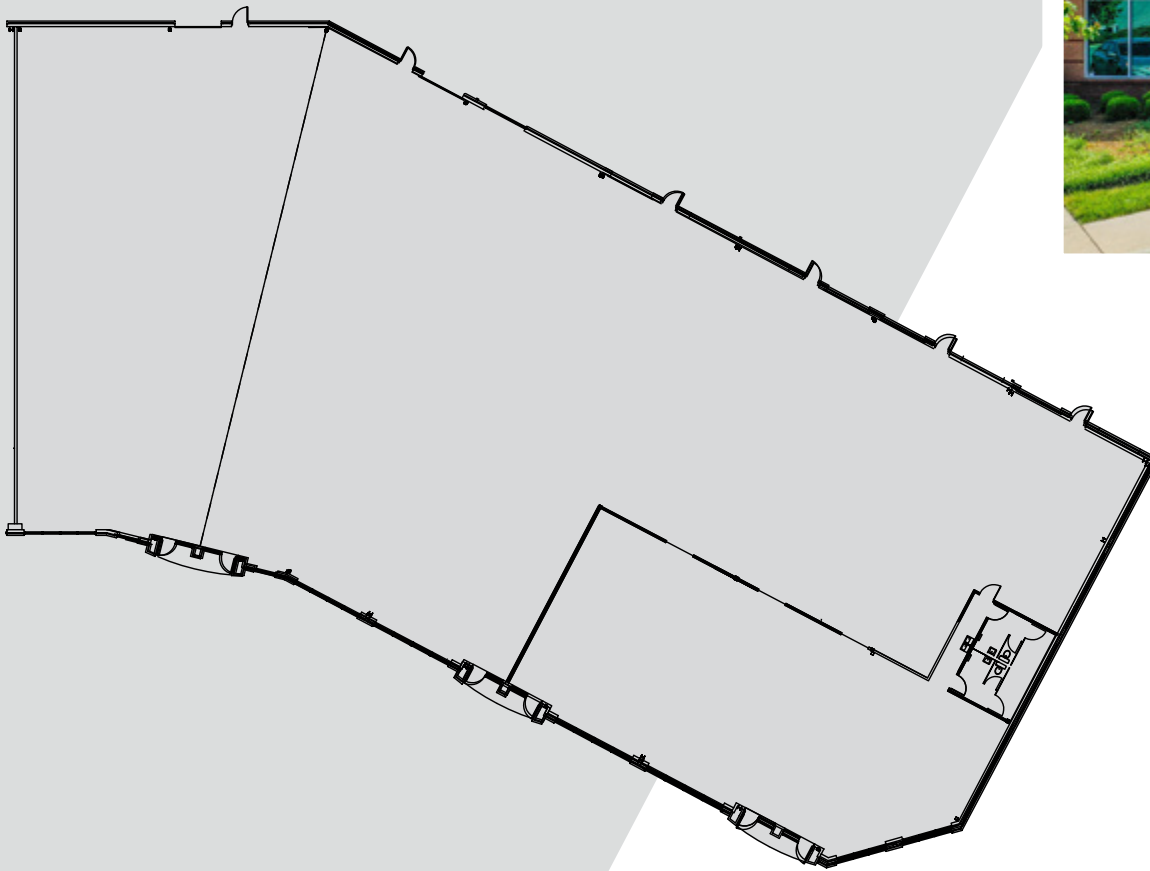



9123 MONROE ROAD - SUITE 110



Total Available SF: SUITE 110 1,850 SF

SUITE 110

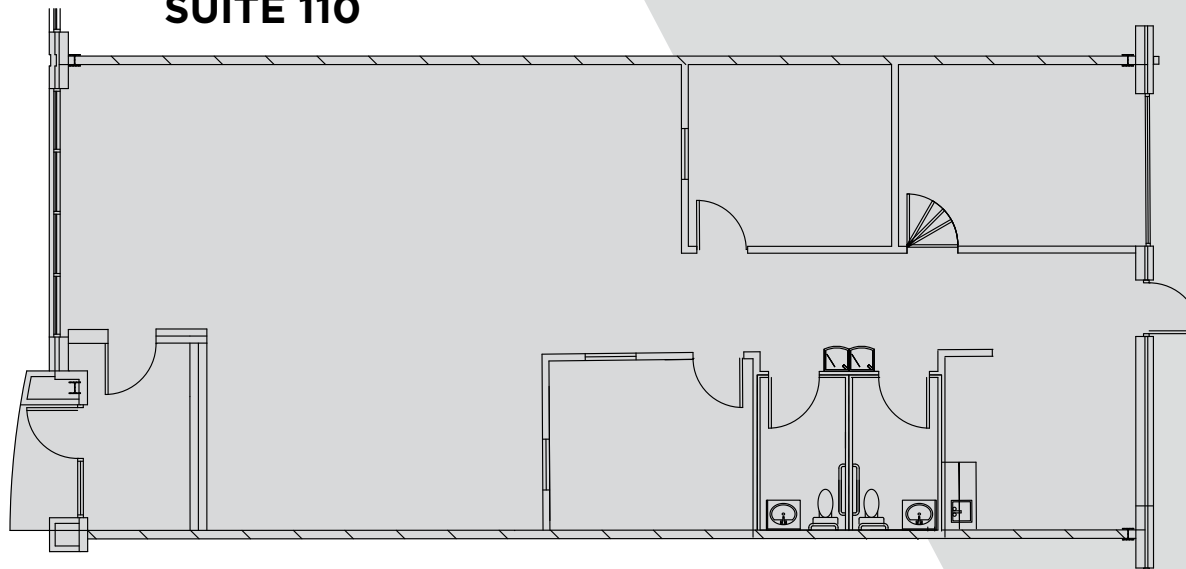



9129 MONROE ROAD - SUITES 135-140



Total Available SF: 8,550 SF

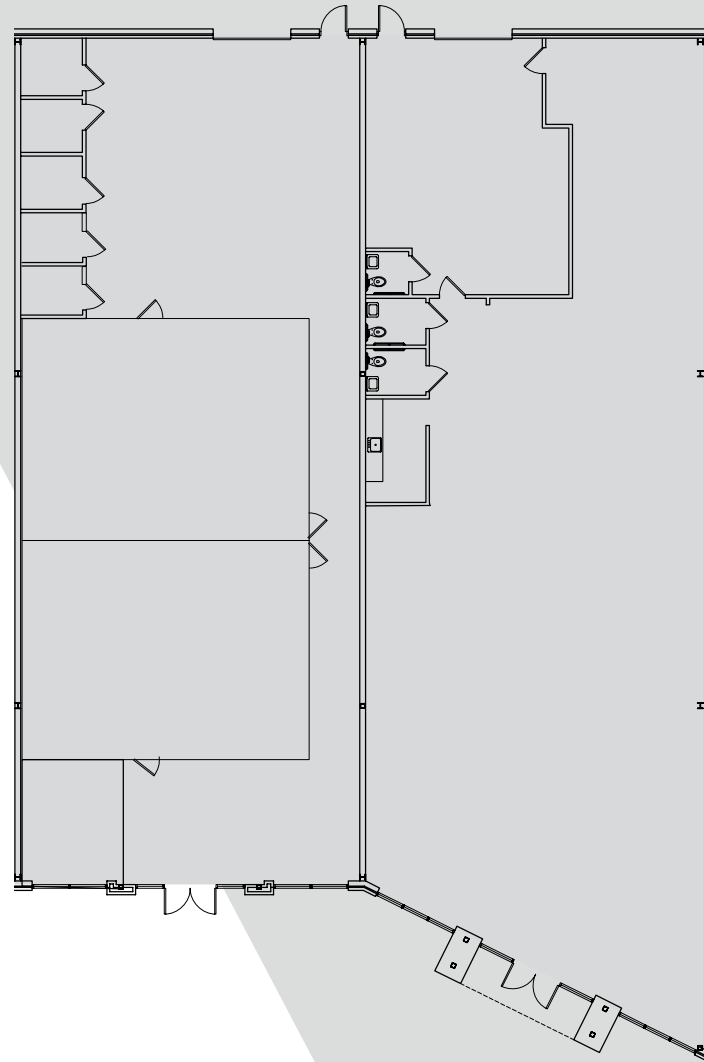



9301 MONROE ROAD - SUITES E & I

SUITE E

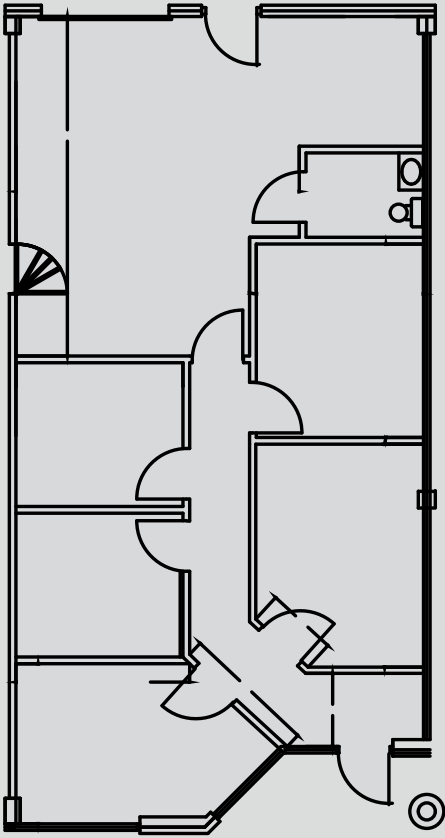

SUITE I

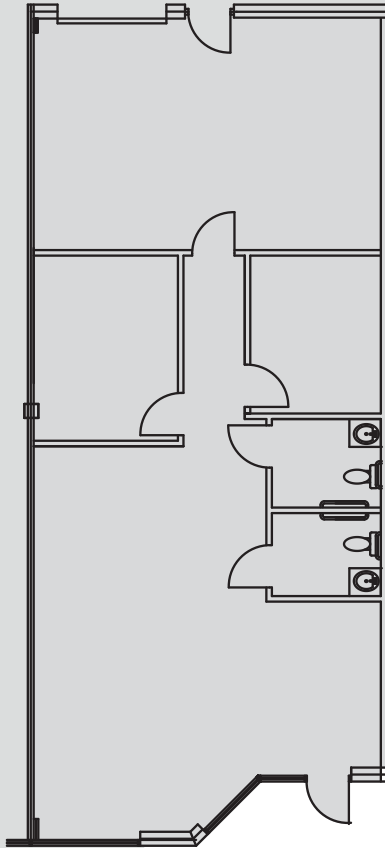

Total Available SF:

SUITE E 1,250 SF
SUITE I 1,500 SF



9303 MONROE ROAD - SUITES L & M



Total Available SF: SUITE L 1,500 SF
 SUITE M 1,500 SF

SUITE L

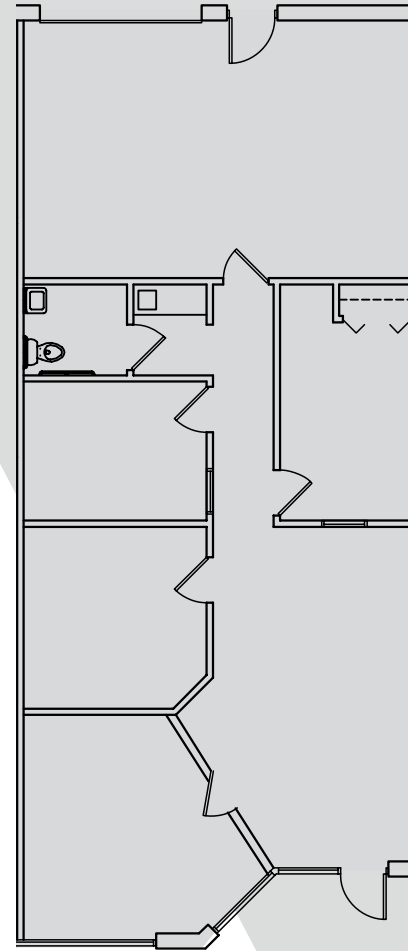

SUITE M

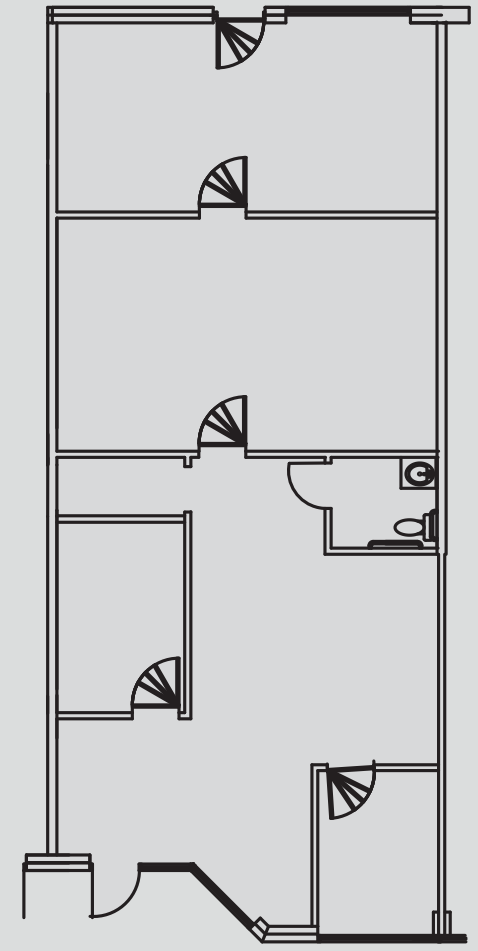



9305 MONROE ROAD - SUITE F

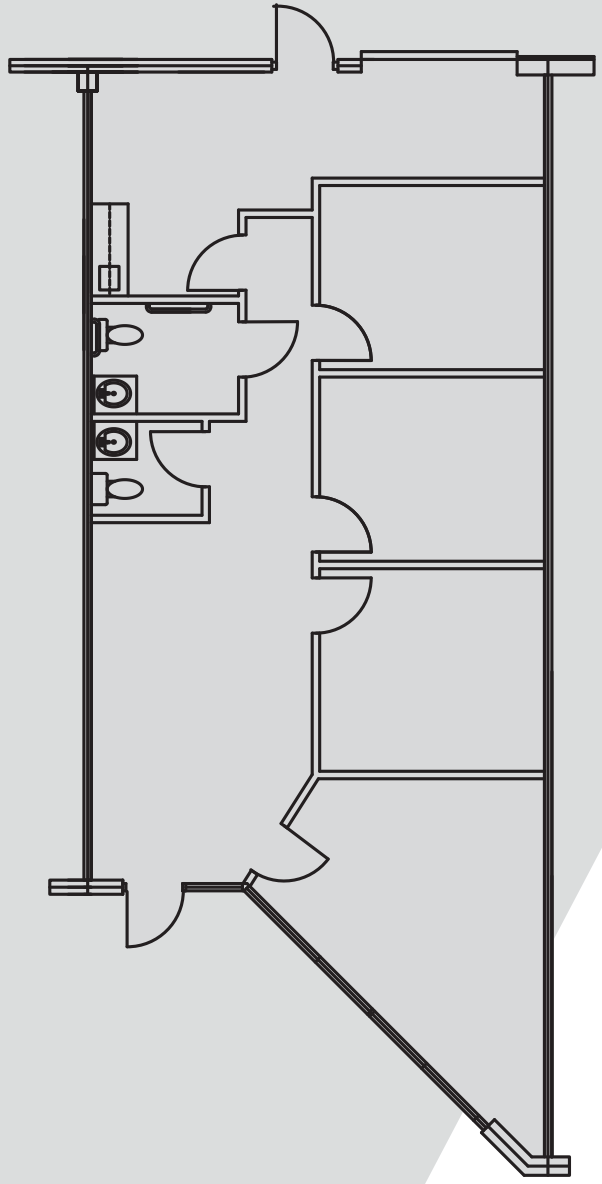

Total Available SF: 1,310 SF





9307 MONROE ROAD - SUITES E, K-L & P



| | | |
|---------------------|-----------|----------|
| Total Available SF: | SUITE E | 1,250 SF |
| | SUITE K&L | 3,000 SF |
| | SUITE P | 1,950 SF |

SUITE E

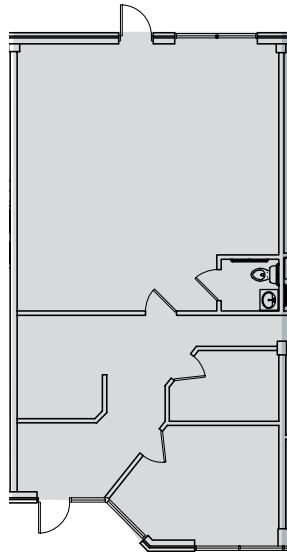

SUITE K&L

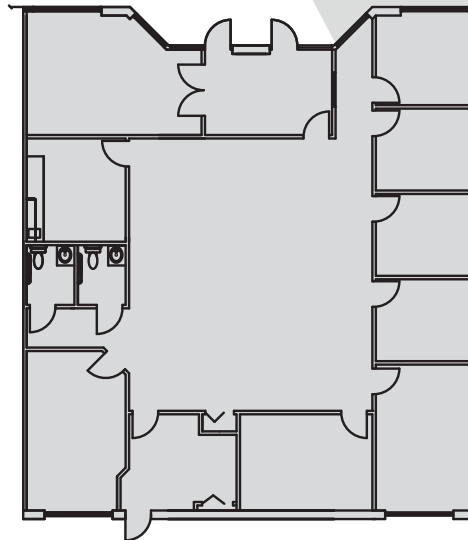

SUITE P

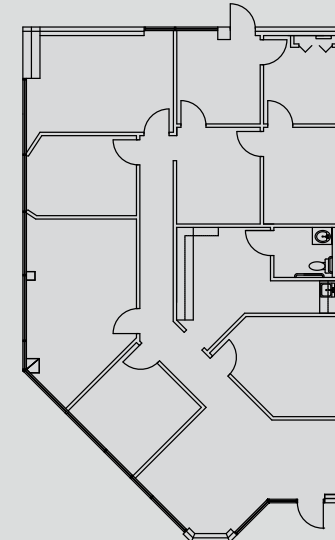



9311 MONROE ROAD - SUITES J & I



| | | |
|----------------------------|----------------|-----------------|
| Total Available SF: | SUITE J | 2,400 SF |
| | SUITE I | 2,400 SF |

SUITE J

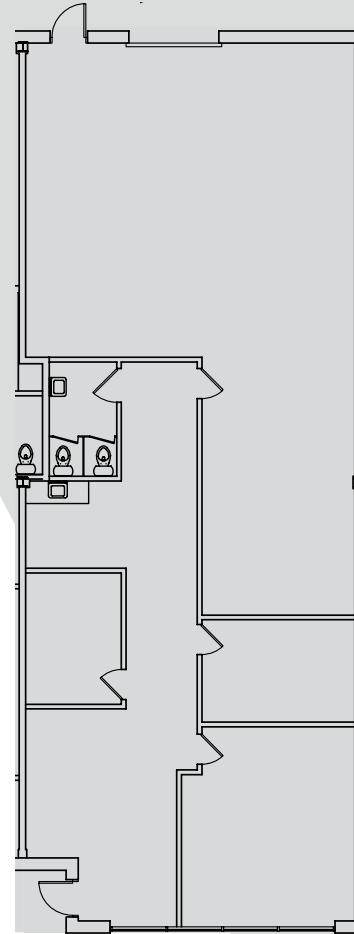

SUITE I

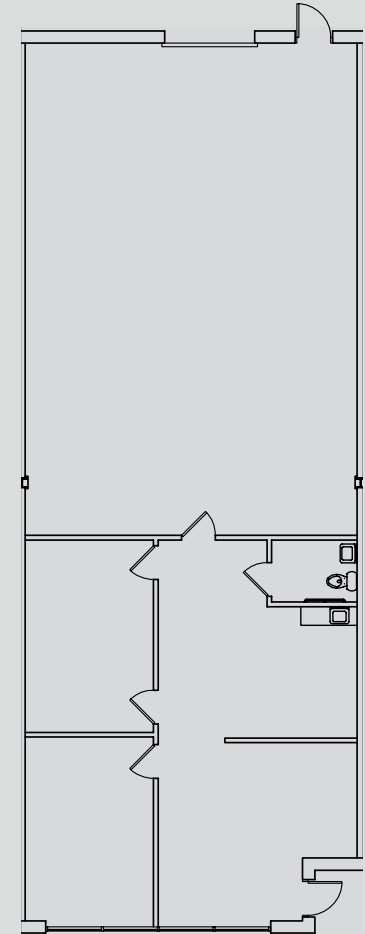



9315 MONROE ROAD - SUITE G & H



Total Available SF: 10,000 SF

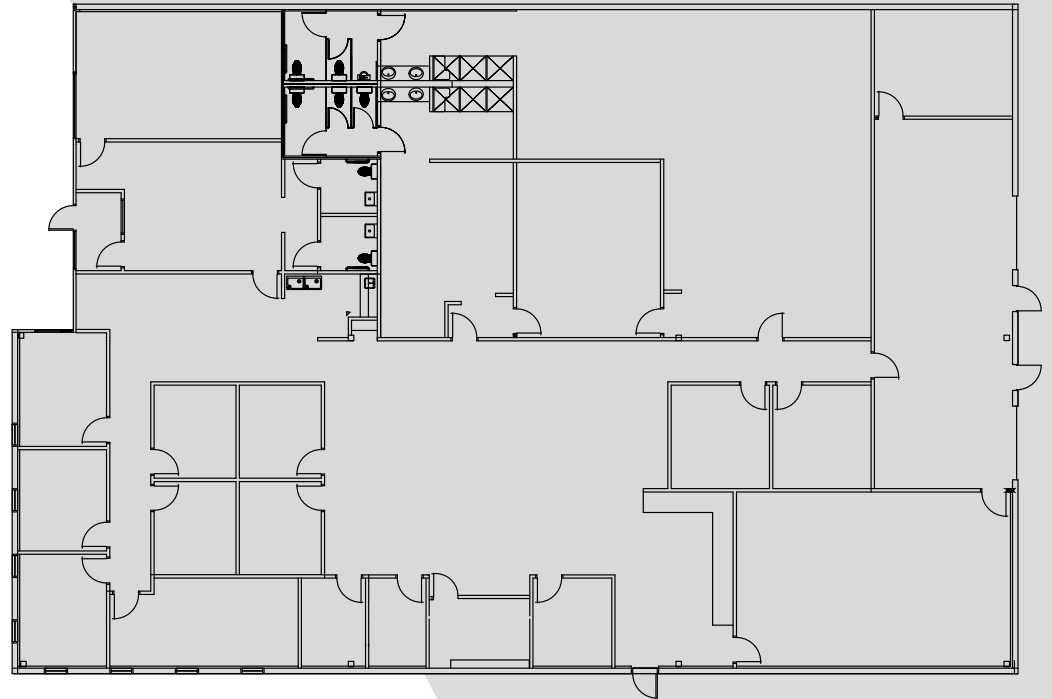



9317 MONROE ROAD - SUITE F, G & H



Total Available SF: 15,000 SF
2 Dock High Doors
1 Drive-In Door
Endcap Unit

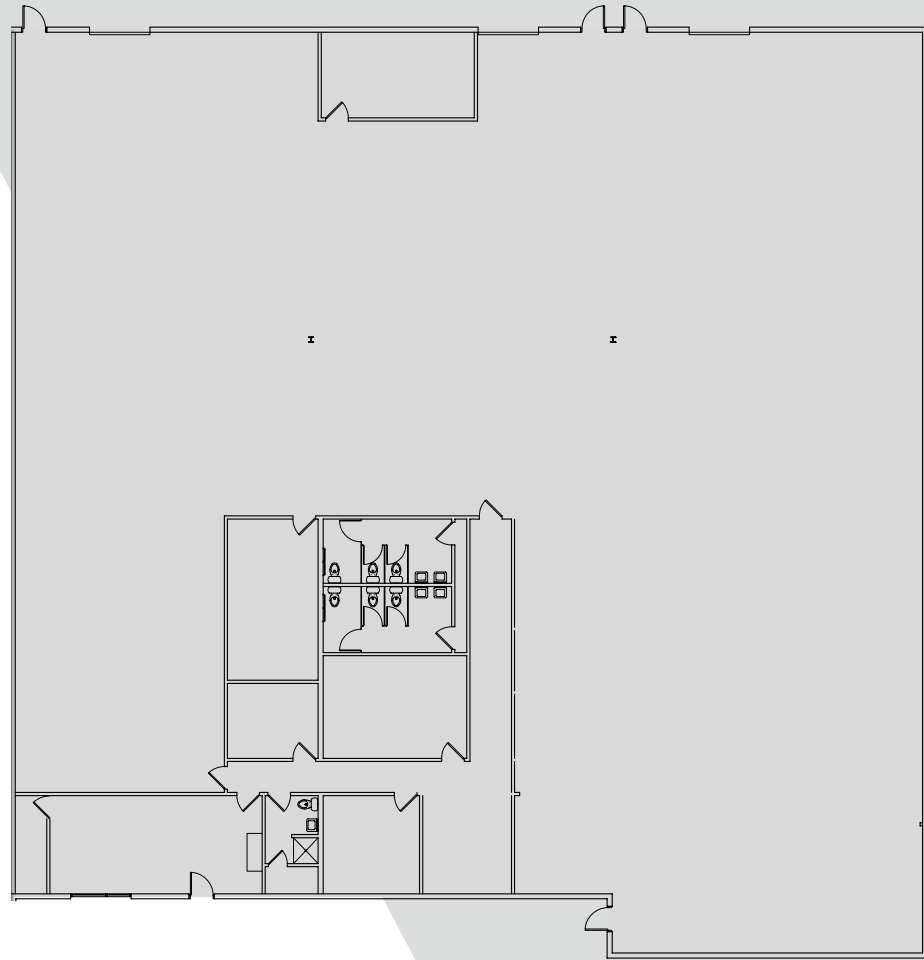

DREW COHOLAN

+1 704 620 6124

drew.coholan@cushwake.com

FRANCES CRISLER

+1 704 620 6014

frances.crisler@cushwake.com

©2021 Cushman & Wakefield. All rights reserved. The information contained in this communication is strictly confidential. This information has been obtained from sources believed to be reliable but has not been verified. No warranty or representation, express or implied, is made as to the condition of the property (or properties) referenced herein or as to the accuracy or completeness of the information contained herein, and same is submitted subject to errors, omissions, change of price, rental or other conditions, withdrawal without notice, and to any special listing conditions imposed by the property owner(s). Any projections, opinions or estimates are subject to uncertainty and do not signify current or future property performance.



GREYLYN

BUSINESS PARK

Charlotte, North Carolina



WESTON



CUSHMAN &
WAKEFIELD