

AVAILABLE FOR SALE OR LEASE

SALE PRICE: \$298,500 | LEASE RATE: \$23.36/SF NNN



TRADITIONAL OFFICE

2158 W EISENHOWER BLVD., SUITE B4, LOVELAND, CO 80537

1,102 SF



2158 W EISENHOWER BLVD., SUITE B4, LOVELAND, CO 80537

PROPERTY HIGHLIGHTS

Discover the unique opportunity to buy, or lease short term if needed, a versatile office space at 2158 W Eisenhower Blvd in Loveland, Colorado. This office is conveniently located near both professional and residential areas, making it ideal for a variety of businesses. The building is situated in a well-trafficked area, providing easy access. The spacious layout includes four private offices, a large conference room, and an inviting reception area with a waiting room. Schedule a showing today to envision your future in this exceptional office space!

NNN Expenses without Utilities:	\$7.67/SF
Building Size:	1,102 SF
Parking:	45 spaces
Year Built:	1998
Private Offices:	4
Zoning:	B - Developing Business 



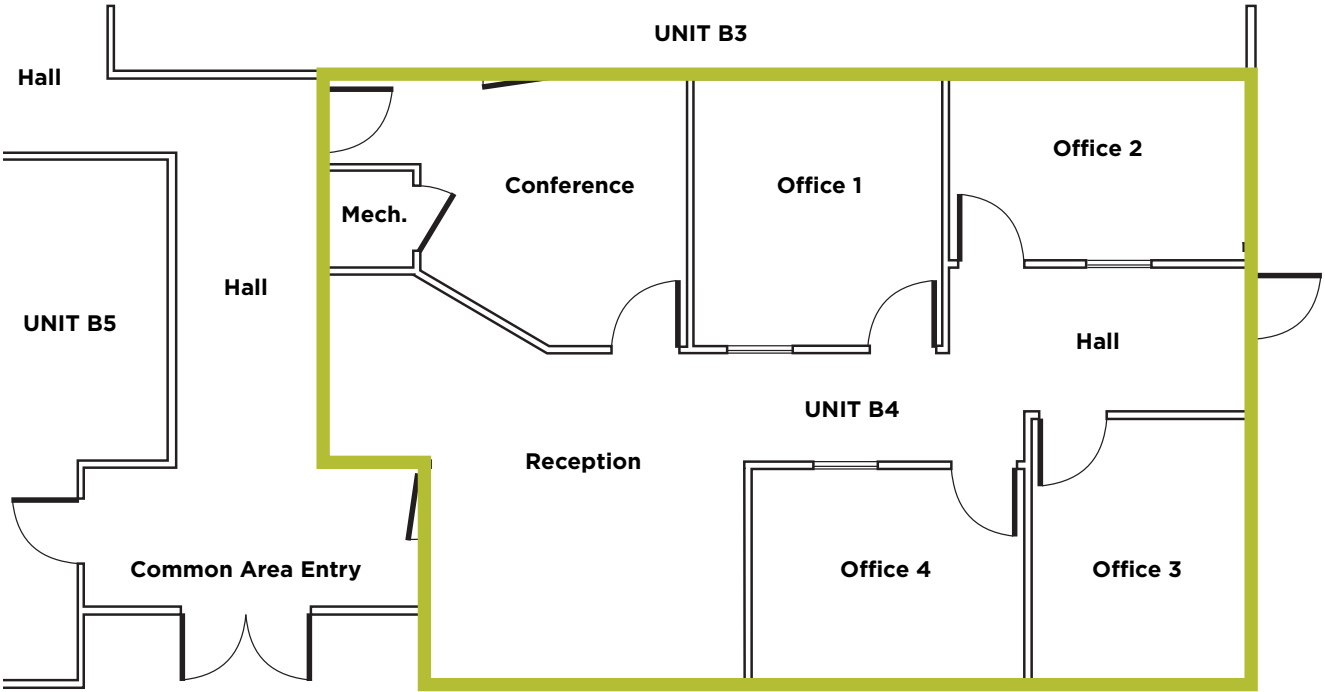
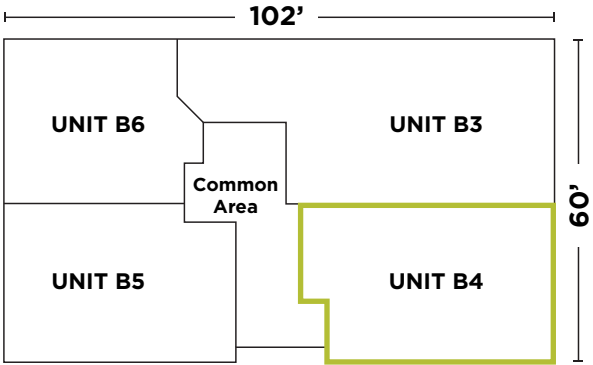

FLOOR PLAN

1,102 SF



**CONTACT
INFORMATION**

NATE HECKEL
Senior Director
970 267 7724
nate.heckel@cushwake.com

TYLER MURRAY
Senior Director
970 267 7404
tyler.murray@cushwake.com

TY MASHEK
Senior Associate
303 525 3125
ty.mashek@cushwake.com

772 Whalers Way, Suite 200
Fort Collins, CO 80525
+1 970 776 3900
cushmanwakefield.com



©2024 Cushman & Wakefield. All rights reserved. The information contained in this communication is strictly confidential. This information has been obtained from sources believed to be reliable but has not been verified. NO WARRANTY OR REPRESENTATION, EXPRESS OR IMPLIED, IS MADE AS TO THE CONDITION OF THE PROPERTY (OR PROPERTIES) REFERENCED HEREIN OR AS TO THE ACCURACY OR COMPLETENESS OF THE INFORMATION CONTAINED HEREIN, AND SAME IS SUBMITTED SUBJECT TO ERRORS, OMISSIONS, CHANGE OF PRICE, RENTAL OR OTHER CONDITIONS, WITHDRAWAL WITHOUT NOTICE, AND TO ANY SPECIAL LISTING CONDITIONS IMPOSED BY THE PROPERTY OWNER(S). ANY PROJECTIONS, OPINIONS OR ESTIMATES ARE SUBJECT TO UNCERTAINTY AND DO NOT SIGNIFY CURRENT OR FUTURE PROPERTY PERFORMANCE